

F

E

D

C

B

A

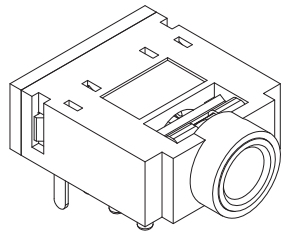

RoHS
Compliant

ZONE	SYMBOL	REVISION	APPROVAL	DATE
		UPDATE THE DWG.	J.X.KUANG	6-2-2012

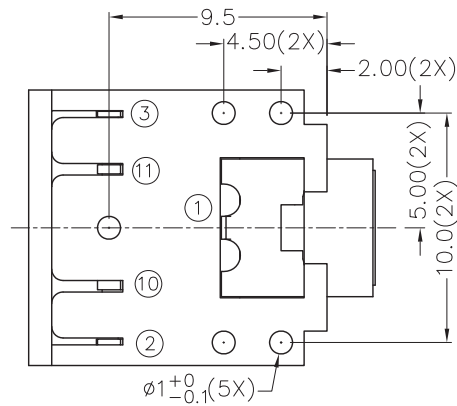
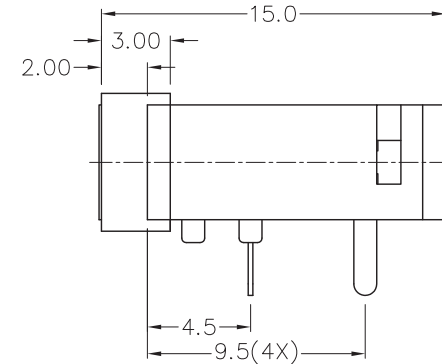
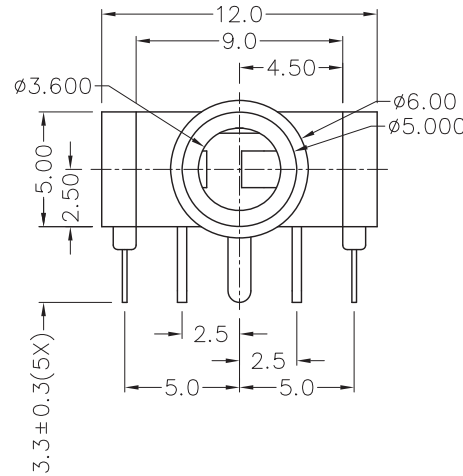
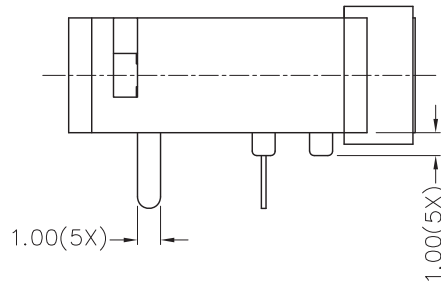

*MATERIAL

- TERMINAL 1 : COPPER ALLOY
- TERMINAL 2 : COPPER ALLOY
- TERMINAL 3 : COPPER ALLOY
- TERMINAL 10 : BRASS
- TERMINAL 11 : BRASS
- BUSHING : BRASS
- HOUSING : PBT
- COVER : PBT

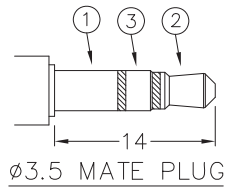
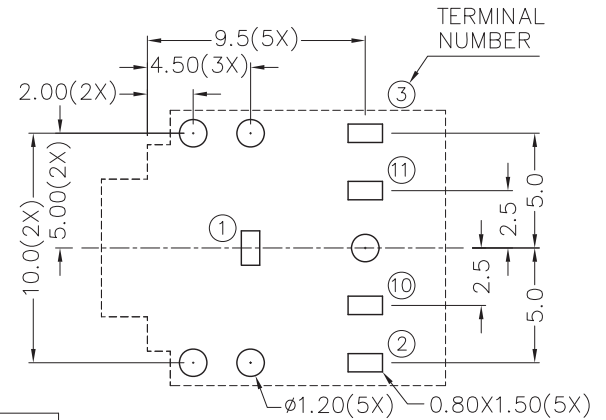

MODEL NO.	TSH-3595C	TSH-3594AC	TSH-3594BC	TSH-3593C	TSH-3593AC
SCHEMATIC					

PCB LAYOUT
(TOP VIEW)



CHAMPWAY 冠泰電子有限公司
CHAMPWAY ELECTRONICS CO., LTD.

DESIGN	L.L.ZHANG	DATE	21-7-2005	SCALE	3:1
DRAWING	CH.XIONG	DATE	6-2-2012	MATERIAL	*
CHECK		DATE		DWG. NO.	TZ\SH359C-PBT/D
APPROVAL		DATE		SHEET	

PART NAME	3.5mm STEREO JACK	TOLERANCE UNLESS	0.0±0.2	UNIT:	
PART NO.	TSH-359C	OTHERWISE SPECIFIED:	0.00±0.1 0.000±0.05		

F

E

D

C

B

A