

NO.	NAME	MATERIAL
1	HOUSING	PBT / Nylon
2	PIN TERM.	PHOS. BRONZE
3	SHELL	BRASS

SUA-110H1 * - * * *

Series

Type

Color

B : Black

W : White

Shell

Z : Nickel Plated (Shiny Surface)

Version

1 : 1.1

2 : 2.0

Material

B : PBT

P : Nylon

REV	ZONE	REVISION	DATE	APPD.

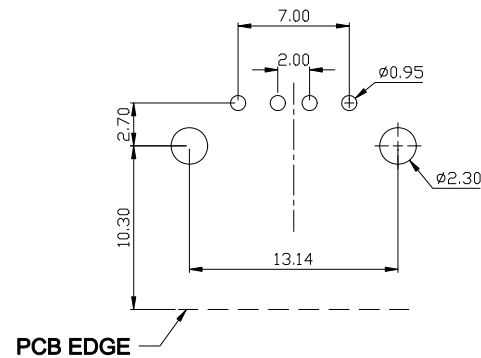
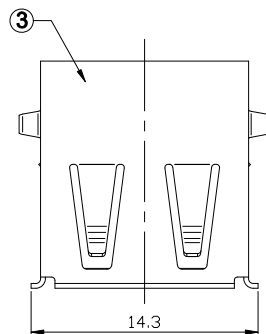
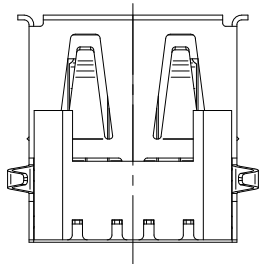
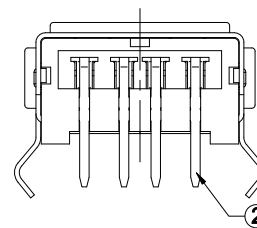
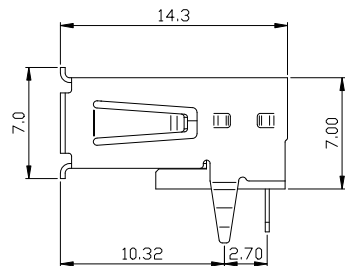
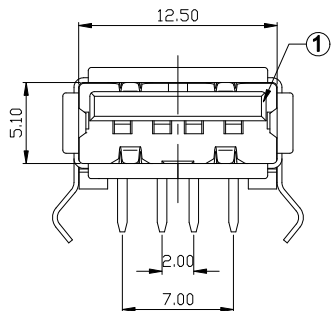

SUGGESTED PCB LAYOUT
TOP VIEW

CHAMPWAY 冠泰电子有限公司
CHAMPWAY ELECTRONICS CO., LTD.

COMPUTER NO.

UNIT

SCALE

PART NAME

D:\DWG\SUA-110H1

mm

1:1

USB. TYPE A
FLAT 90° DIP

APPD.

CKD.

DWG.

DATE

TOLERANCE

REV.

MODEL

SUA-110H1 * - * * *

PAGE 1 OF 1

Aaron

Eric

2010-05-28

0.000mm ± 0.075mm
0.00 mm ± 0.15 mm
0.0 mm ± 0.25 mm

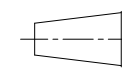

A.0