

NO.	NAME	MATERIAL
1	HOUSING	PBT / Nylon
2	PIN TERM.	PHOS. BRONZE
3	SHELL COVER	BRASS / SPCC
4	SHELL	BRASS
5	HOUSING COVER	PBT/Nylon

# SUA-110V\*-\*-\*

Series  
Type  
Color  
B : Black  
W : White

Shell  
T : Tin Plated  
F : SPCC  
N : Nickel Plated (Foggy Surface)

Version  
1 : 1.1  
2 : 2.0

Material  
B : PBT  
P : Nylon

REV	ZONE	REVISION	DATE	APPD.
A.1	(A)	增加Foggy Surface敘述	2009.3.23	Aaron

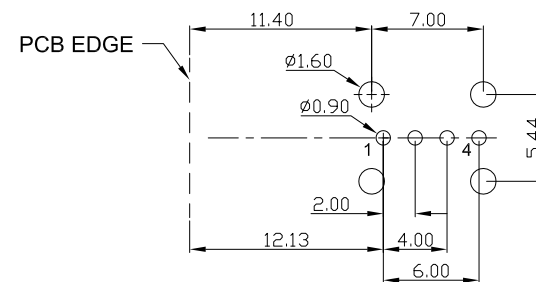
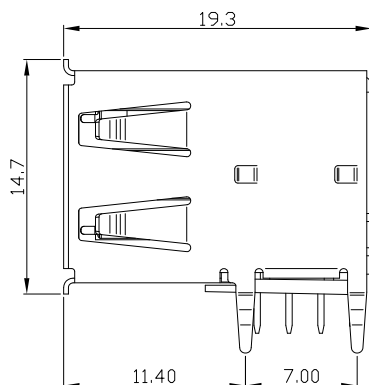
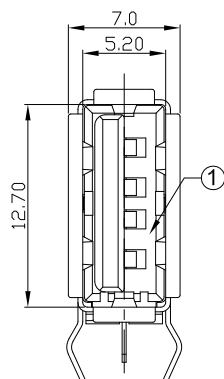

**SUGGESTED PCB LAYOUT  
TOP VIEW**

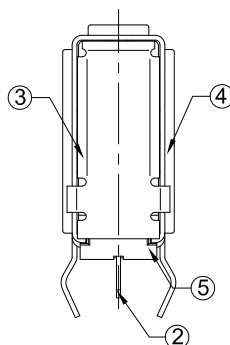
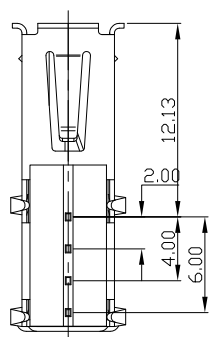

**CHAMPWAY** 冠泰電子有限公司  
CHAMPWAY ELECTRONICS CO., LTD.

COMPUTER NO.

UNIT

SCALE

PART NAME

D : \ DWG \ SUA-110V

mm

1 : 1

USB. TYPE A  
UPRIGHT 90° DTP

APPD.

CKD.

DWG.

DATE

TOLERANCE

REV.

MODEL

SUA-110V\*-\*-\*

PAGE 1 OF 1

Michael

Valiant

2007-02-14

0.000mm ± 0.075mm  
0.00 mm ± 0.15 mm  
0.0 mm ± 0.25 mm

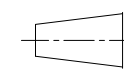

A.1