

RevNo	Revision note	Date	Signature

NOTE

1. RATING : DC 12V 50mA
2. CONTACT RESISTANCE : 100mΩMAX
3. GENERAL TOLERANCE : +/- 0.3 mm
4. MANUFACTURING SPECIFICATION WOULD BE ACCORDANCE WITH WT0158
5. PART NO.(P/N.):

TS601VH - * * * R - B

6.0X6.0
VERTICAL

DIMENSION "H"

- 043=4.3mm
- 045=4.5mm
- 050=5.0mm
- 055=5.5mm
- ...

OPERATING FORCE

- A=100gf
- B=160gf
- C=260gf
- ...

STEM COLOR

- =BLACK
- N=BROWN
- R=RED
- ...

PACKING
B=BAG

TS601VH-170**R-B	17.0 mm
TS601VH-130**R-B	13.0 mm
TS601VH-125**R-B	12.5 mm
TS601VH-120**R-B	12.0 mm
TS601VH-115**R-B	11.5 mm
TS601VH-110**R-B	11.0 mm
TS601VH-105**R-B	10.5 mm
TS601VH-100**R-B	10.0 mm
TS601VH-095**R-B	9.5 mm
TS601VH-090**R-B	9.0 mm
TS601VH-085**R-B	8.5 mm
TS601VH-080**R-B	8.0 mm
TS601VH-075**R-B	7.5 mm
TS601VH-070**R-B	7.0 mm
TS601VH-065**R-B	6.5 mm
TS601VH-060**R-B	6.0 mm
TS601VH-055**R-B	5.5 mm
TS601VH-050**R-B	5.0 mm
TS601VH-045**R-B	4.5 mm
TS601VH-043**R-B	4.3 mm
MODEL NO.	"H"

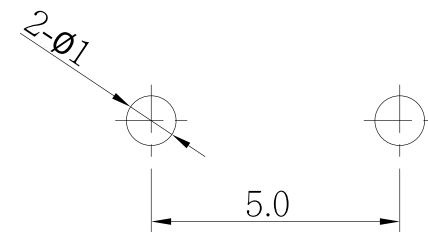
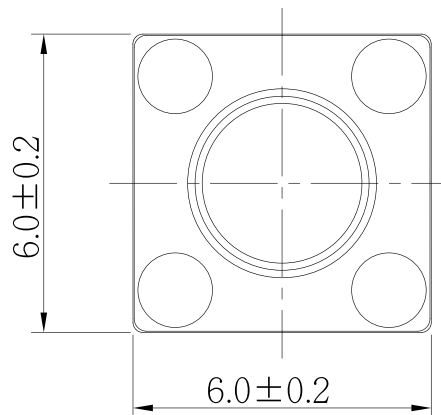

P.C.B LAND DIMENSION

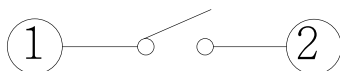
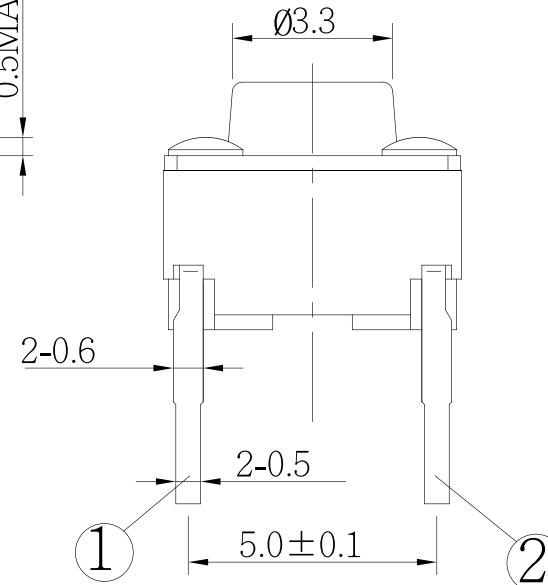
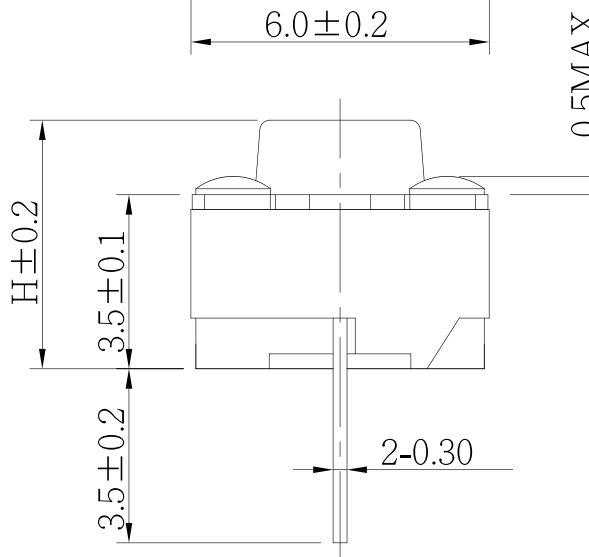

CIRCUIT DIAGRAM

Designed by	L.Y.D		 冠泰電子有限公司 CHAMPWAY ELECTRONICS CO., LTD.						
Checked by			Unit	mm	Scale	1/1	Date	2011.10.14	
Approved by		Item	Tactile Switch		Tool	Sheet	1/1	Rev.	0
Model	6.0X6.0 Through Hole	Drawing name	TS601VH- * * * R-B						